

Australian Government Primary Principals Association



Robert Randall CEO
Tuesday 28 July 2015

Overview of presentation

- The Australian Curriculum
- NAPLAN online
- ACARA and AGPPA

Australian Curriculum Review

- Work to improve the Australian Curriculum addressing themes identified by the Education Council:
 - uncrowding the curriculum
 - rebalancing the curriculum
 - improving accessibility for students with disability
 - parental engagement.

Resolving the overcrowded curriculum

- Main focus on primary curriculum
- Volume of content in learning areas has been reduced by deleting, clarifying and simplifying content descriptions, where appropriate, and moving reference to examples for inclusion by teachers to the content elaborations
- Redesigning humanities and social sciences (incorporating history, geography, civics and citizenship and economics and business) into one learning area for primary years
- Provision of single learning area achievement standards in addition to the existing subject-specific achievement standards in the learning areas of humanities and social sciences, the arts and technologies
- Ensuring the general capabilities and cross curriculum priorities are appropriately tagged to learning areas

Rebalancing the Australian Curriculum

- Strengthening phonics and phonemic awareness in the Australian Curriculum: English
- Streamlining of the identification of general capabilities and cross curriculum priorities
- Strengthening of the representation of Western influences on Australia's system of government

Supporting info on the AC website

- Links to the *Melbourne Declaration* and the *Shape of the Australian Curriculum*
- Reductions in the volume of supporting information for each learning area
- Reducing repetition and consolidating the *F-10 overview*
- Consistent navigational headings ... to find information more easily

Accessibility and parental engagement

Improving accessibility

- Nine options identified; three with broad support

Parental access

- Consulting with agencies who have completed similar work and engaging with other key stakeholders
- Developing proposals to improve parent engagement followed.

Moving to NAPLAN Online

Advantages of moving online

- NAPLAN online will provide **better assessment, more precise results** and **faster turnaround** of information.
- NAPLAN online will mean that the tests **better meet the needs of all** students, including those with a disability.
- NAPLAN online will use adaptive **‘tailored testing design’** which gives students questions better **suited to their achievement level**, resulting in better assessment and **more precise results**.

Why computer adaptive (TTD) testing?

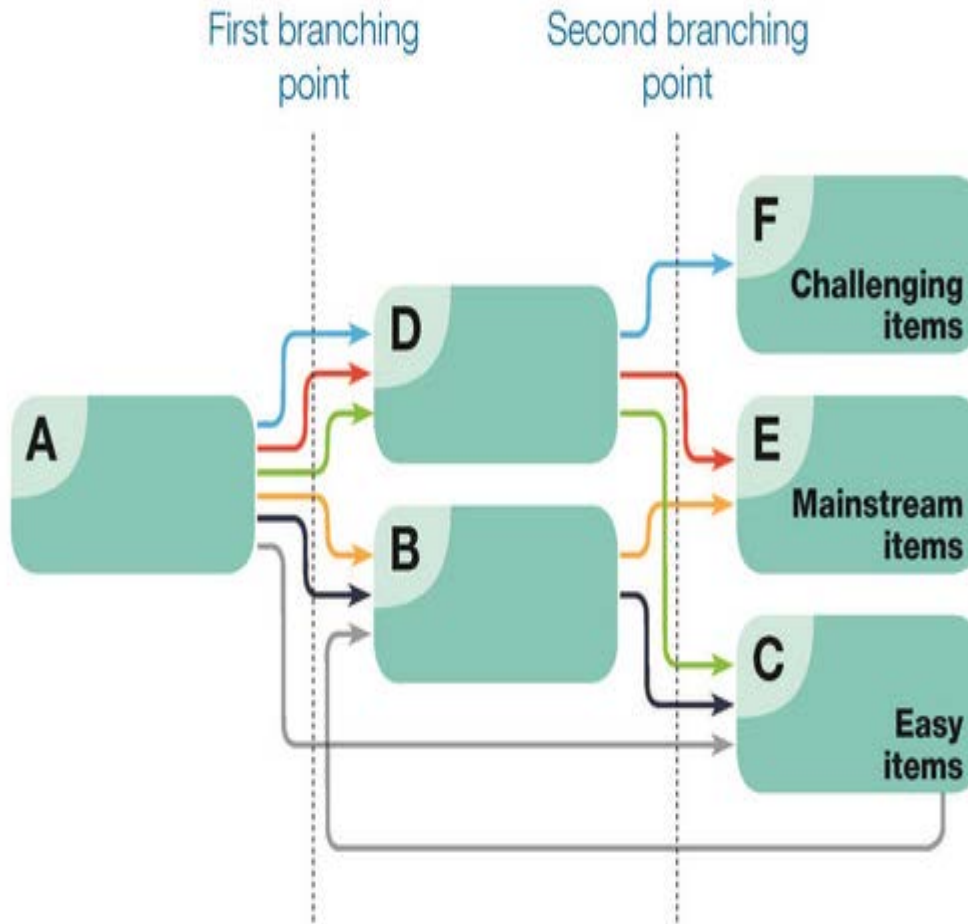

NAPLAN Online research program

- Essential studies to move online
- Informed by “best practice in Australia and internationally
- Therefore every study focuses on 4 key questions:
 - What does the research show?
 - What are the “lessons learned” in other programs?
 - How do these “lessons” apply to the Australian/NAPLAN context?
 - How do “real” students react when they sit for online items (Cognitive Interviews)

NAPLAN Online research program

- **Trialling study:** ensure all item types (traditional and innovative) work in the online environment
- **Device effect** study: no disadvantage laptop vs tablet (with or without detachable keyboards) vs paper
- **Fonts and readability** study: best layout for reading test (passages and items)
- **Accessibility** study: test fair for all students (SWDs, remote, etc.)
- **Autoscoreing** study: need to demonstrate that computer can score NAPLAN writing as well as teachers
- Findings from the **NAP Sample** Program: place to test new item types and online platform itself

ACARA and AGPPA working together

Keeping in touch

- ACARA Update
- Stakeholder briefings
- Social media



@ACARAeduau and @ACARA_CEO



ACARAeduau



ACARAeduau



ACARAeduau



ACARAeduau

Thank you

